



Despiece

Spare parts list

Vué explosée

Ricambi

Gewerbetrockner

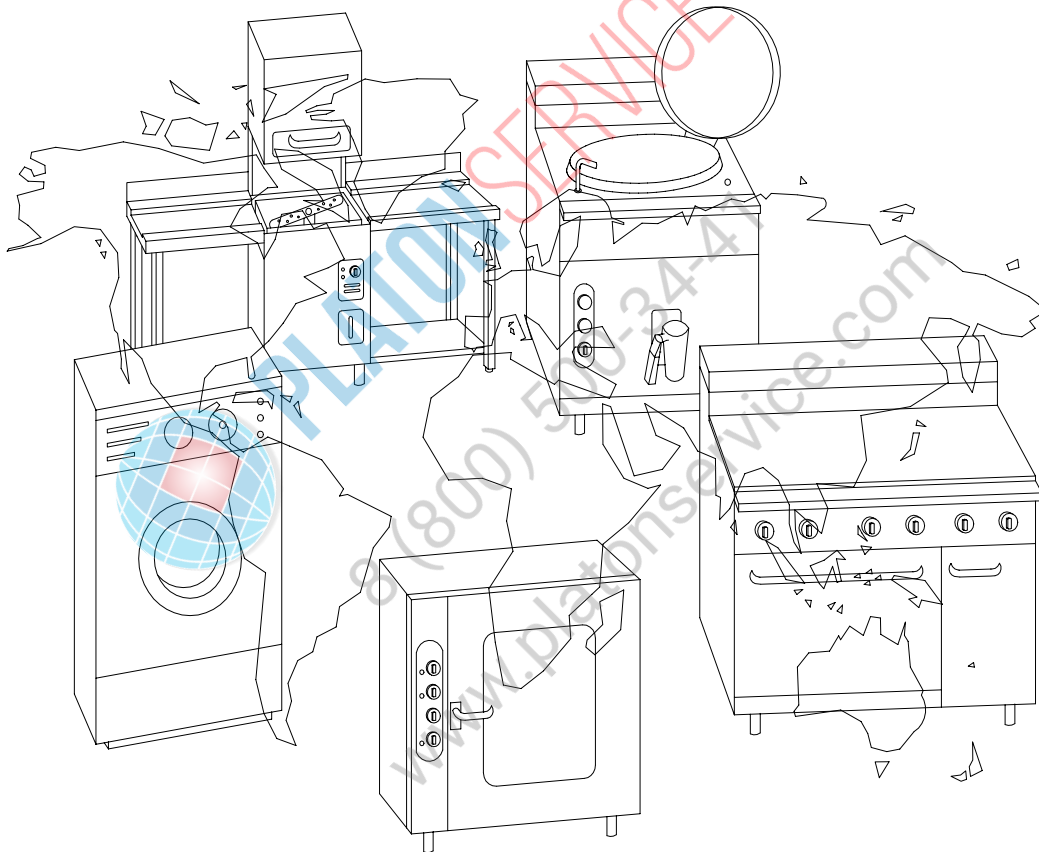

SECADORAS DIGITALES / DIGITAL TUMBLE DRYERS / SCHEUSES DIGITAL

MODELS: **SR-10**
 SR-10 MP
 SR-13
 SR-13 MP

Enero 2013
January 2013

ANALOGIC BODY / MUEBLE ANALOGICO / CARROZZERIA ANALOGICO / ENSEMBLE ANALOGIC / ANALOGKASTEN

Pos.	Código	10	13	Description	Descripción	Descrizione	Désignation	Bezeichnung
1	00V00023	1	1	Back lids reinforcement	Refuerzo tapas posteriores	Schiena centrale	Renfort couvercles arrière	Verstärkung hintere deckel
2	00V00028	1	1	Back superior lid	Tapa posterior superior	Schiena superiore	Couvercle arrière supérieur	Oberer hinterdeckel
3	00V00029	1	1	Back inferior lid	Tapa posterior inferior	Schiena inferiore	Couvercle arrière inférieur	Unterer hinterdeckel
4	00V00069	1	1	Front pannel joint	Unión tapa intermedia	Pannello ass.vasca/ frontale	Assemble panneau frontale	Verbindung mitteldeckel
5	00V04003	1	1	Battery thermic protection lid	Tapa protección térmica batería	Pannello protezione termica	Couvercle protection thermique	Deckel thermoschutz der batterie
6	00V00053	1	1	Inlet hoop	Aro refuerzo entrada	Anello circolare carico oblò	Cercle entrée	Eingangsverstärkungsring
7	07V00181	1	1	Fluff filter lid	Tapa filtro borra	Pannello ispezione filtro	Couvercle filtre bourre	Flugfilterdeckel
8	07V00168	1		Ceiling 10	Techo 10	Coperchio 10	Plafond 10	Plafond 10
	07V10168	1		Ceiling 13	Techo 13	Coperchio 13	Plafond 13	Plafond 13
9	07V00225	1	1	Front panel	Tapa frontal	Pannello frontale	Panneau frontale	Mitteldeckel
10	1BC03036	4	4	Levelling feet	Pies nivelación	Piedini regolabili	Pieds de nivellement	Nivellierfüsse
11	1BJ07520	2	2	Thermostat timer	Mando reloj/termostato	Comando orologio/termostato	Pouvoir horloge/thermostat	Thermostat-zeitregler
12	1DG11130	1	1	Thermostat cap. 2,9 M.INV 90°	Termostato cap. 2,9 M.INV 90°	Termostato cap. 2,9 M.INV 90°	Thermostat cap. 2,9 M.INV 90°	Thermostat Kap. 2,9 M INV 90°
13	1DG11154	1	1	Safety thermostat 180°	Termostato seguridad 180°	Termostato sicurezza 180°	Thermostat sécurité 180°	Sicherheitsthermostat 180°
14	1DI13315	1	1	Clock with delay 60"	Reloj con retardador de 60"	Orologio con fa ritardare 60"	Horloge avec retardateur 60"	Zeituhr verzögerung 60"
15	1FB02235	2	2	Door magnet Ø20	Imán puerta Ø20	Oblò magnete Ø20	Magnetique porte Ø20	Türmagnet Ø20
16	1DK13104	1	1	Emergency push-button	Pulsador paro emergencia	Pulsante emergenza completo	Bouton d'urgence	Notstoppdruckknopf
17	1DK13106	1	1	Emergency stop adhesive	Anagrama paro emergencia	Targa "Emergency Stop"	Anagramme arrêt d'urgence	Notstoppanagramm
18	1DK13111	1	1	Reset rectangular button (Gas)	Pulsador reset rectangular (Gas)	Pulsante reset (Gas)	Bouton reset rectangulaire (Gaz)	Rechtekiger reset-druckknopf (Gas)
19	1DK13240	1	1	Green light push-button	Pulsador bipolar luminoso verde	Pulsante luce verde	Pulsateur bipolaire lumineux vert	Grünleuchtender bipolarer druckknopf
20	1DL15029	1	1	Caps top PG-29 (Electric)	Prensa estopa PG-29 (Eléctrico)	Passa cavo PG-29 (Electric)	Passe fil électrique PG-29 (Électrique)	Anschlussleitung PG-29 (Elektrische)
21	1DL15021	1	1	Caps top PG-16 (Gas-Steam)	Prensa estopa PG-16 (Gas-Vapor)	Passa cavo PG-16 (Gas-Vapore)	Passe fil électrique PG-16 (Gaz-Vapore)	Anschlussleitung PG-16 (Gas-dampfheizung)
22	1DL14313	1	1	Green pilot D13	Piloto D13 verde	Pilota D13 verde	Pilote D13 vert	Warnlampe grün D13
23	1DL14315	2	2	Red pilot D13	Piloto D13 rojo	Pilota D13 rosso	Pilote D13 rouge	Warnlampe rot D13
24	1FB03060	2	2	Fluff filter lid handle	Tirador tapa filtro borra	Maniglia pannello filtro	Poignée couvercle filtre bourre	Griff des flugfilterdeckels
25	1FB02233	1	1	Door magnet Ø13	Imán puerta Ø13	Oblò magnete Ø13	Magnetique porte Ø13	Türmagnet Ø13
26	80V10133	1	1	Fluff filter	Filtro borra	Filtro aria	Filtre bourre	Flugfilter
27	1BC03225	2	2	Clip lock	Cierre clip	Clip serratura	Serrure clip	Verriegelung
28	1BC03224	2	2	Receptacle clip	Receptáculo clip	Clip contenitore	Réceptacle clip	Uhrengehäuse
29	1DG11734	2	2	Reed Cylinder sensor	Sensor reed cilíndrico	Reed cylinder sensore	Reed capteur	Reed aufnehmer
30	00V02170	2	2	Micro holder	Chapa soporte micro reed	Micro sostegno	Micro support	Micro ständer
31	1BE7130L	1	1	Rubber profile	Perfil goma tapa filtro	Profilo in gomma	Profil de caoutchoue	Gummiprofil
32	07V00150	1	1	Controler lid	Tapa portamandos digital	Pannello	Couvercle	Deckel

ANALOGIC BODY
 MUEBLE ANALÓGICO
 CARROZZERIA ANALOGICO
 ENSEMBLE ANALOGIC
 ANALOGKASTEN

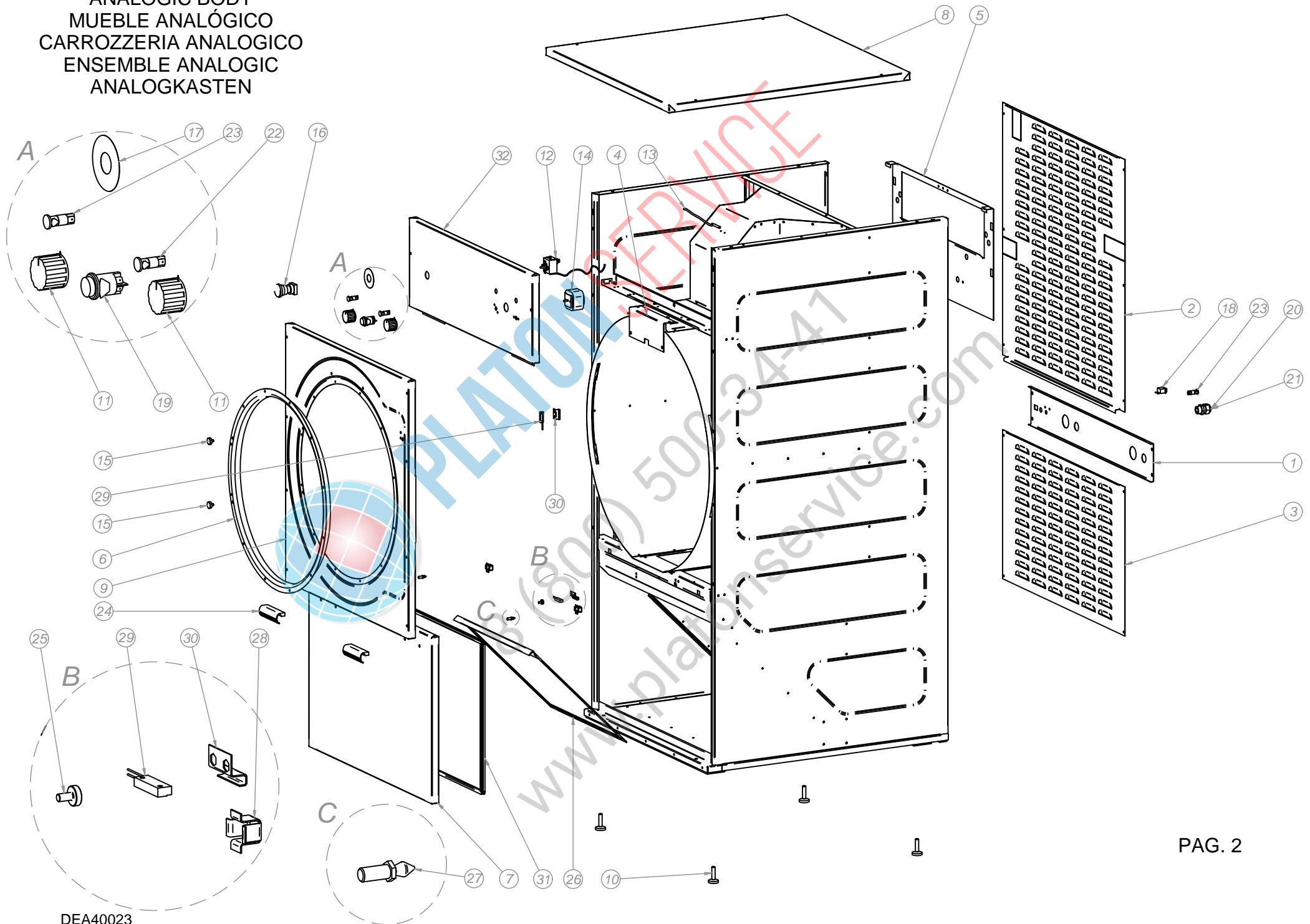

DIGITAL BODY / MUEBLE DIGITAL / CARROZZERIA DIGITAL / MEUBLE DIGITAL / DIGITALKASTEN

Pos.	Código	10	13	Description	Descripción	Descrizione	Désignation	Bezeichnung
1	00V00023	1	1	Back lids reinforcement	Refuerzo tapas posteriores	Schiena centrale	Renfort couvercles arrière	Verstärkung hintere deckel
2	00V00028	1	1	Back superior lid	Tapa posterior superior	Schiena superiore	Couvercle arrière supérieur	Oberer hinterdeckel
3	00V00029	1	1	Back inferior lid	Tapa posterior inferior	Schiena inferiore	Couvercle arrière inférieur	Unterer hinterdeckel
4	00V00069	1	1	Front panel joint	Unión tapa intermedia	Pannello ass.vasca/frontale	assemble panneau frontale	Verbindung mitteldeckel
5	00V04003	1	1	Battery thermic protection lid	Tapa protección térmica batería	Pannello protezione termica	Couvercle protection thermique	Deckel thermoschutz der batterie
6	00V000...	1	1	Inlet hoop	Aro refuerzo entrada	Anello circolare carico oblò	Cercle entrée	Eingangsverstärkungsring
7	07V00181	1	1	Fluff filter lid	Tapa filtro borra	Pannello ispezione filtro	Couvercle filtre bourre	Flugfilterdeckel
8	07V00168	1		Ceiling 10	Techo 10	Coperchio 10	Plafond 10	Plafond 10
	07V00181	1		Ceiling 13	Techo 13	Coperchio 13	Plafond 13	Plafond 13
9	07V00225	1	1	Front panel	Tapa frontal	Pannello frontale	Panneau frontale	Mitteldeckel
10	1BC03036	4	4	Levelling feet	Pies nivelación	Piedini regolabili	Pieds de nivellement	Nivellierfüsse
11	1DH12206	1	1	MP microprocessor	Microprocesador MP	Microprocessore MP	Microprocesseur MP	Mikroprozessor MP
12	1DH12314	2	2	Micro. temperature sound	Sonda temperatura microprocesador	Sonda temperatura micro.	Sonde température microprocesseur	Temperaturfühler f.mikroprozessor
13	1DG11154	1	1	Safety thermostat 180°	Termostato seguridad 180°	Termostato di sicurezza	Thermostat sécurité 180°	Sicherheitsthermostat 180°
14	00V00126	2	2	Support of MP microprocessor	Soporte microprocesador MP	Sostegno microprocessore MP	Support du microprocesseur	Ständer für den Mikroprozessor MP
15	1FB02235	2	2	Door magnet Ø20	Imán puerta Ø20	Oblò magneti Ø20	Magnetique porte Ø20	Türmagnet Ø20
16	1DK13104	1	1	Emergency push-button	Pulsador paro emergencia	Pulsante emergenza completo	Bouton d'urgence	Notstoppdruckknopf
17	1DK13106	1	1	Emergency stop adhesive	Anagrama paro emergencia	Targa "Emergency Stop"	Anagramme arrêt d'urgence	Notstoppanagramm
18	1DK13111	1	1	Reset rectangular button (Gas)	Pulsador reset rectangular (Gas)	Pulsante reset (Gas)	Bouton reset rectangulaire (Gaz)	Rechteckiger reset-druckknopf (Gas)
19	1BH07458	1	1	Stiker	Stiker	Stiker	Stiker	Stiker
20	1DL15029	1	1	Caps top PG-29 (Electric)	Prensa estopa PG-29 (Eléctrico)	Passa cavo PG-29 (Electric)	Passe fil électrique PG-29 (Électrique)	Anschlussleitung PG-29 (Elektrische)
21	1DL15021	1	1	Caps top PG-16 (Gas-Steam)	Prensa estopa PG-16 (Gas-Vapor)	Passa cavo PG-16 (Gas-Vapore)	Passe fil électrique PG-16 (Gaz-Vapore)	Anschlussleitung PG-16 (Gas-dampfheizung)
22	1DL14315	1	1	Green pilot D13	Piloto D13 verde	Pilota D13 verde	Pilote D13 vert	Warnlampe grün D13
23	1FB03060	2	2	Fluff filter lid handle	Tirador tapa filtro borra	Maniglia pannello filtro	Poignée couvercle filtre bourre	Griff des flugfilterdeckels
24	1FB02233	1	1	Door magnet Ø13	Imán puerta Ø13	Oblò magneti Ø13	Magnetique porte Ø13	Türmagnet Ø13
25	80V00133	1	1	Fluff filter	Filtro borra	Filtro aria	Filtre bourre	Flugfilter
26	1BC03225	2	2	Clip lock	Cierre clip	Clip serratura	Serrure clip	Verriegelung
27	1BC03224	2	2	Receptacle clip	Receptáculo clip	Clip contenitore	Réceptacle clip	Uhrengehäuse
28	1DG11734	2	2	Reed Cylinder sensor	Sensor reed cilíndrico	Reed cylinder sensore	Reed capteur	Reed aufnehmer
29	00V02170	2	2	Micro holder	Chapa soporte micro reed	Micro sostegno	Micro support	Micro ständer
30	1BE7130L	1	1	Rubber profile	Perfil goma tapa filtro	Profilo in gomma	Profil de caoutchouc	Gummiprofil
31	07V00940	1	1	Controler lid	Tapa portamandos digital	Pannello	Couvercle	Deckel

DIGITAL BODY
 MUEBLE DIGITAL
 CARROZZERIA DIGITAL
 ENSEMBLE DIGITAL
 DIGITALKASTEN

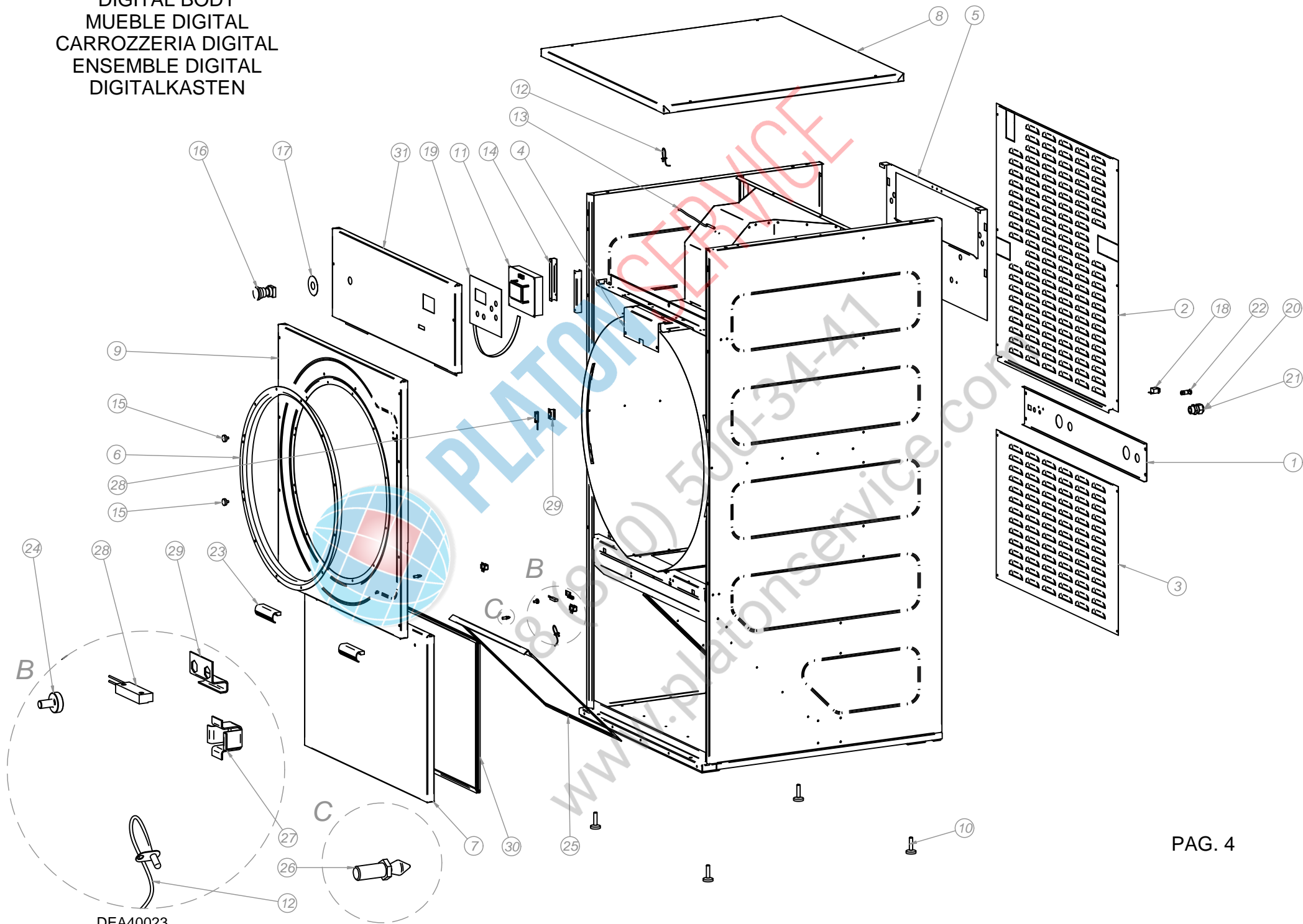

DEA40023

ANALOGIC ELECTRIC BOX / CUADRO ELECTRICO ANALOGICO/ QUADRO ELETTRICO ANALOGICO / TABLEAU ELECTRIQUE ANALOGIC / ANALOGSCHALTТАFEL (PAG.6)
ELECTRICAL HEATING / CALEFACCION ELECTRICA / RISCALDAMENTO ELETTRICO / CHAUFFAGE ELECTRIQUE / ELEKTRISCHE HEIZUNG

Pos.	Código	10	13	Description	Descripción	Descrizione	Désignation	Bezeichnung
1	00V00024	1	1	Electric box	Cuadro eléctrico	Piastra porta cablaggio	Tableau électrique	Schalttafel
3	1DC00001	1	1	Frequency control 0,37 kW	Variador frecuencia 0,37 kW	Variatore di frequenza 0,37 kW	Variateur fréquence 0,37 kW	Frequenzumformer 0,37 kW
5	1DC01050	2	2	Universal RC filter 220V	Filtro RC universal 220V	Filtro RC 220V	Filtre RC universel 220V	Universal RC filter 220V
6	1DF10131	1	1	Fan contactor	Contactador ventilador	Mini contattore	Contacteur ventilateur	Schaltenschutz ventilator
7	1DF10136	1	1	Resistors contactor	Contactador resistencias	Contattore resistenze	Contacteur résistances	Schaltenschutz widerstand
8	1DI12320	1	1	Timer 4 functions	Temporizador 4 funciones	Funzioni del temporizzatore	Temporisateur	Funktionen des timers
9	1DL14150	3	3	Connection boxes 4/6 mm	Regleta conexión 4/6 mm	Connettore plastica 4/6 mm	Réglette connexion 4/6 mm	Anschlussleiste 4/6 mm
10	1DL14156	1	1	Boxes lid 4/6 mm	Tapa regleta 4/6 mm	Fianco di chiusura 4/6 mm	Plateau réglette 4/6 mm	Deckel f.Anschlussleiste 4/6 mm
11	1DL14162	2	2	End stop	Tope final	Terminale plastica	Arrêtoir final	Endstopp
12	1DL14203	2	2	Fuse housing lane 35	Portafusible carril 35	Portafusibile 8,5x31,5	Porte-fusible rail 35	Sicherungshalter schiene 35
13	1DL14280	2	2	Fuse cartridge 2Amp	Cartucho fusible 2Amp	Fusibile ceramica 2Amp	Cartouche fusible 2Amp	Sicherungspatrone 2Amp
14	1DL14251	2	2	Fuse cartridge 10Amp	Cartucho fusible 10Amp	Fusibile ceramica 10Amp	Cartouche fusible 10Amp	Sicherungspatrone 10Amp
15	1AB01439	1	1	Diferential air pressure	Presostato diferencial	Pressostato differenziale	Pressostat différentiel	Differentialdruckmesser
16	1DL14152	5	5	Connection boxes 16/25 mm	Regleta conexión 16/25 mm	Connettore plastica 16/25 mm	Réglette connexion 16/25 mm	Anschlussleiste 16/25 mm
17	1DL14158	1	1	Boxes lid 16/25 mm	Tapa regleta 16/25 mm	Fianco di chiusura 16/25 mm	Plateau réglette 16/25 mm	Deckel f.Anschlussleiste 16/25 mm



8 (800) 300444
www.platonservizi.com

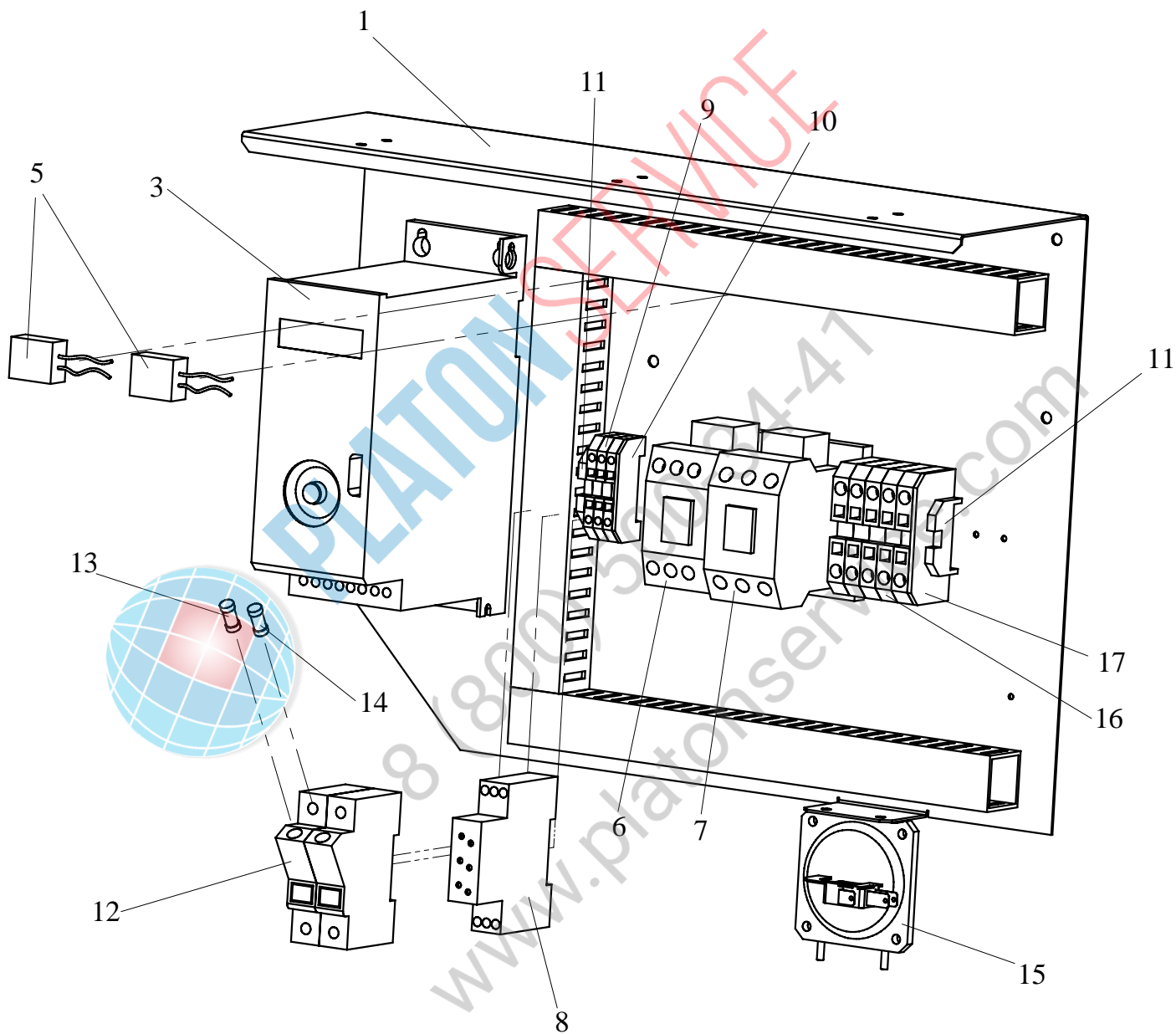

ANALOGIC ELECTRIC BOX / CUADRO ELECTRICO ANALOGICO/ QUADRO ELETTRICO ANALOGICO / TABLEAU ELECTRIQUE ANALOGIC / ANALOGSCHALTAFEL
 GAS-STEAM HEATING / CALEFACCION GAS-VAPOR / RISCALDAMENTO GAS-VAPORE / CHAUFFAGE GAZ-VAPEUR / GAS-DAMPFHEIZUNG

Pos.	Código	10	13	Description	Descripción	Descrizione	Désignation	Bezeichnung
1	00V00024	1	1	Electric box	Cuadro eléctrico	Piastra porta cablaggio	Tableau électrique	Schalttafel
3	1DC00001	1	1	Frequency control 0,37 kW	Variador frecuencia 0,37 kW	Variatore di frequenza 0,37 kW	Variateur fréquence 0,37 kW	Frequenzumformer 0,37 kW
5	1DC01050	1	1	Universal RC filter 220V	Filtro RC universal 220V	Filtro RC 220V	Filtre RC universel 220V	Universal RC filter 220V
6	1DF10131	1	1	Fan contactor	Contactador ventilador	Mini contattore	Contacteur ventilateur	Schaltenschutz ventilator
8	1DI12320	1	1	Timer 4 functions	Temporizador 4 funciones	Funzioni del temporizzatore	Temporisateur	Funktionen des timers
9	1DL14150	6	6	Connection boxes 4/6 mm	Regleta conexión 4/6 mm	Connettore plastica 4/6 mm	Réglette connexion 4/6 mm	Anschlussleiste 4/6 mm
10	1DL14156	2	2	Boxes lid 4/6 mm	Tapa regleta 4/6 mm	Fianco di chiusura 4/6 mm	Plateau réglette 4/6 mm	Deckel f. Anschlussleiste 4/6 mm
11	1DL14162	2	2	End stop	Tope final	Terminale plastica	Arrêtoir final	Endstopp
12	1DL14203	2	2	Fuse housing lane 35	Portafusible carril 35	Portafusibile 8,5x31,5	Porte-fusible rail 35	Sicherungshalter schiene 35
13	1DL14280	2	2	Fuse cartridge 2Amp	Cartucho fusible 2Amp	Fusibile ceramica 2Amp	Cartouche fusible 2Amp	Sicherungspatrone 2Amp
14	1DL14251	2	2	Fuse cartridge 10Amp	Cartucho fusible 10Amp	Fusibile ceramica 10Amp	Cartouche fusible 10Amp	Sicherungspatrone 10Amp
15	1AB01439	1	1	Diferential air pressure	Presostato diferencial	Pressostato differenziale	Pressostat différentiel	Differentialdruckmesser



8 (800) 500-44-47
 www.platonservice.com

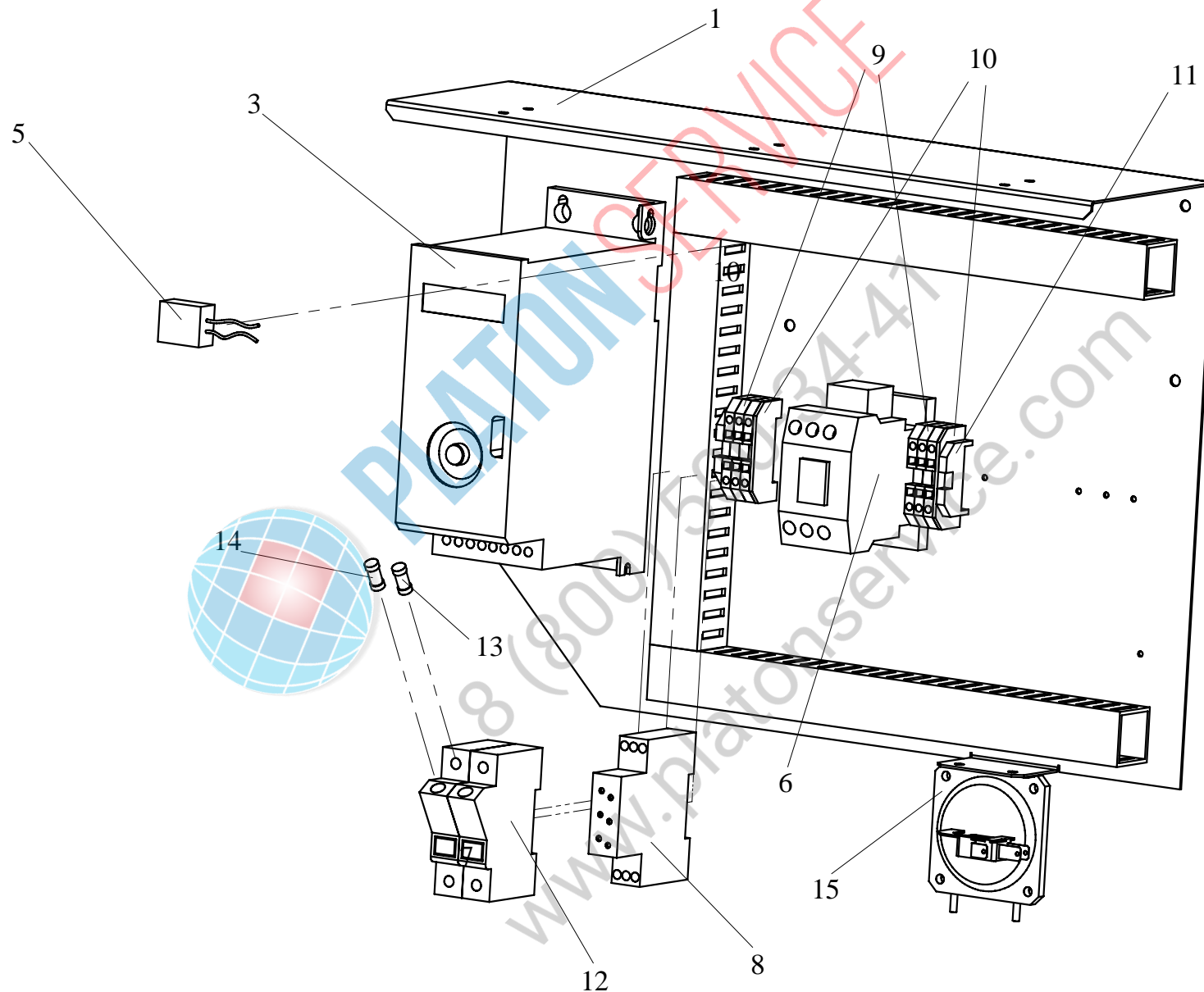

**DIGITAL ELECTRIC BOX / CUADRO ELECTRICO DIGITAL / QUADRO ELETTRICO / TABLEAU ELECTRIQUE DIGITAL / DIGITALSCHALTТАFEL
ELECTRICAL HEATING / CALEFACCION ELECTRICA / RISCALDAMENTO ELETTRICO / CHAUFFAGE ELECTRIQUE / ELEKTRISCHE HEIZUNG**

Pos.	Código	10	13	Description	Descripción	Descrizione	Désignation	Bezeichnung
1	00V00024	1	1	Electric box	Cuadro eléctrico	Piastra porta cablaggio	Tableau électrique	Schalttafel
3	1DC00001	1	1	Frequency control 0,37 kW	Variador frecuencia 0,37 kW	Variatore di frequenza 0,37 kW	Variateur fréquence 0,37 kW	Frequenzumformer 0,37 kW
5	1DC01050	2	2	Universal RC filter 220V	Filtro RC universal 220V	Filtro RC 220V	Filtre RC universel 220V	Universal RC Filter 220V
6	1DF10131	1	1	Fan contactor	Contactador ventilador	Mini contattore	Contacteur ventilateur	Schaltenschutz ventilator
7	1DF10136	1	1	Resistors contactor	Contactador resistencias	Contattore resistenze	Contacteur résistances	Schaltenschutz Widerstand
8	1DL14150	4	4	Connection boxes 4/6 mm	Regleta conexión 4/6 mm	Connettore plastica 4/6 mm	Réglette connexion 4/6 mm	Anschlussleiste 4/6 mm
9	1DL14156	1	1	Boxes lid 4/6 mm	Tapa regleta 4/6 mm	Fianco di chiusura 4/6 mm	Plateau réglette 4/6 mm	Deckel f. Anschlussleiste 4/6 mm
10	1DL14162	1	1	End stop	Tope final	Terminale plastica	Arrêteoir final	Endstopp
11	1DL14203	2	2	Fuse housing lane 35	Portafusible carril 35	Portafusibile 8,5x31,5	Porte-fusible rail 35	Sicherungshalter schiene 35
12	1DL14280	2	2	Fuse cartridge 2Amp	Cartucho fusible 2Amp	Fusibile ceramica 2Amp	Cartouche fusible 2Amp	Sicherungspatrone 2Amp
13	1DL14251	2	2	Fuse cartridge 10Amp	Cartucho fusible 10Amp	Fusibile ceramica 10Amp	Cartouche fusible 10Amp	Sicherungspatrone 10Amp
14	1AB01439	1	1	Diferential air pressure	Presostato diferencial	Pressostato differenziale	Pressostat différentiel	Differentialdruckmesser
15	1DL14152	5	5	Connection boxes 16 mm	Regleta conexión 16 mm	Connettore plastica 16 mm	Réglette connexion 16 mm	Anschlussleiste 16 mm
16	1DL14158	1	1	Boxes lid 16 mm	Tapa regleta 16 mm	Fianco di chiusura 16 mm	Plateau réglette 16 mm	Deckel f. Anschlussleiste 16 mm
17	1DH12229	1	1	Source of electricity	Fuente alimentación	Alimentatore	Alimentation électrique	Netzteil

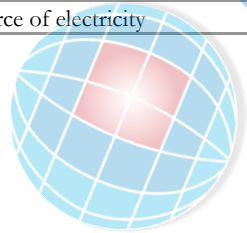

8 (800) 010444
www.platonservizi.com

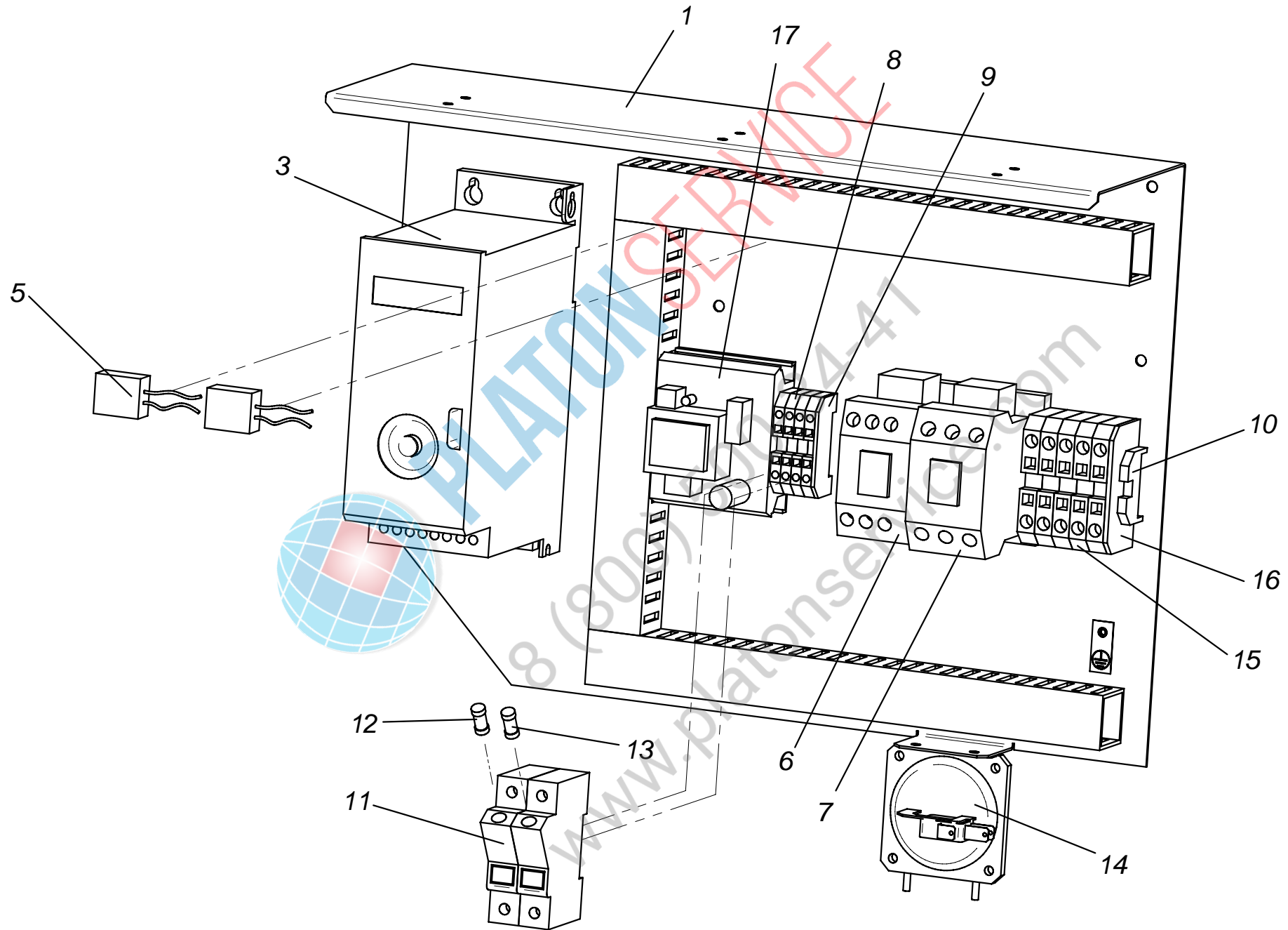

**DIGITAL ELECTRIC BOX / CUADRO ELECTRICO DIGITAL / QUADRO ELETTRICO / TABLEAU ELECTRIQUE DIGITAL / DIGITALSCHALTAFEL
GAS-STEAM FEATING / CALEFACCION GAS-VAPOR / RISCALDAMENTO GAS-VAPORE / CHAUFFAGE GAZ-VAPEUR / GAS-DAMPFHEIZUNG**

Pos.	Código	10	13	Description	Descripción	Descrizione	Désignation	Bezeichnung
1	00V00024	1	1	Electric box	Cuadro eléctrico	Piastra porta cablaggio	Tableau électrique	Schalttafel
3	1DC00001	1	1	Frequency control 0,37 kW	Variador frecuencia 0,37 kW	Variatore di frequenza 0,37 kW	Variateur fréquence 0,37 kW	Frequenzumformer 0,37 kW
5	1DC01050	1	1	Universal RC filter 220V	Filtro RC universal 220V	Filtro RC 220V	Filtre RC universel 220V	Universal RC filter 220V
6	1DF10131	1	1	Fan contactor	Contactador ventilador	Mimi contattore	Contacteur ventilateur	Schalerschutz ventilator
7	1DH12229	1	1	Source of electricity	Fuente alimentación	Alimentatore	Alimentation électrique	Netzteil
8	1DL14150	7	7	Connection boxes 4/6 mm	Regleta conexión 4/6 mm	Connettore plastica 4/6 mm	Réglette connexion 4/6 mm	Anschlussleiste 4/6 mm
9	1DL14156	2	2	Boxes lid 4/6 mm	Tapa regleta 4/6 mm	Fianco di chiusura 4/6 mm	Plateau réglette 4/6 mm	Deckel f.anschlussleiste 4/6 mm
10	1DL14162	1	1	End stop	Tope final	Terminale plastica	Arrêteoir final	Endstopp
11	1DL14203	2	2	Fuse housing lane 35	Portafusible carril 35	Portafisibile 8,5x31,5	Porte-fusible rail 35	Sicherungshalter schiene 35
12	1DL14280	2	2	Fuse cartridge 2Amp	Cartucho fusible 2Amp	Fusibile ceramica 2Amp	Cartouche fusible 2Amp	Sicherungspatrone 2Amp
13	1DL14251	2	2	Fuse cartridge 10Amp	Cartucho fusible 10Amp	Fusibile ceramica 10Amp	Cartouche fusible 10Amp	Sicherungspatrone 10Amp
14	1AB01439	1	1	Diferential air pressure	Presostato diferencial	Pressostato differenziale	Pressostat différentiel	Differentialdruckmesser



8 (800) 500-447
www.platonservice.com

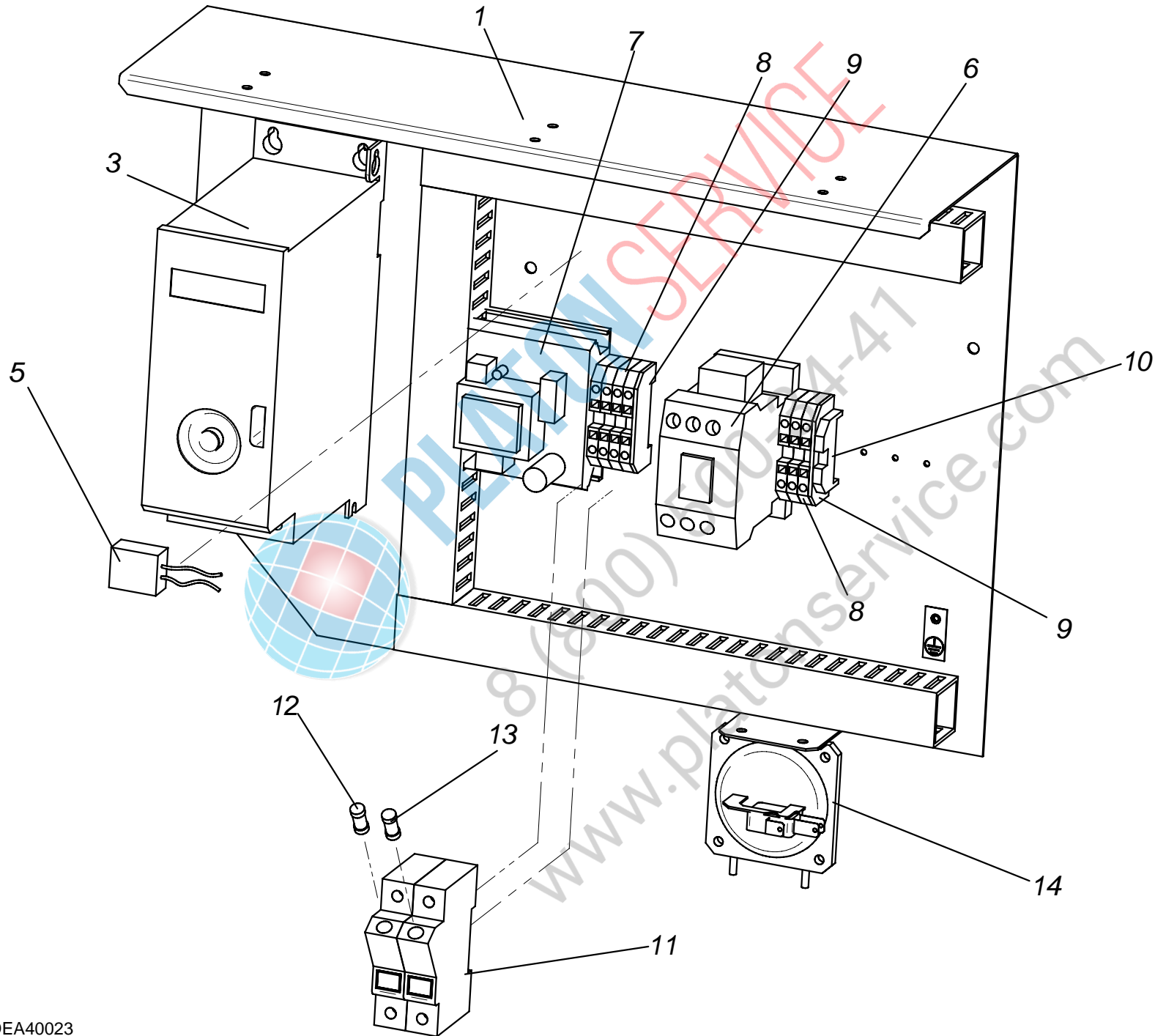

ELECTRICAL HEATING / BATERIA ELECTRICA / BATTERIA ELETTRICA / CHAUFFAGE ELECTRIQUE / ELEKTRISCHE HEIZUNG

Pos.	Código	10	13	Description	Descripción	Descrizione	Désignation	Bezeichnung
1	00V03010	1	1	Electric battery box	Caja batería eléctrica	Schiena batteria elettrica	Boîte batterie électrique	Elektrische batterie gehäuse
2	00V03011	1	1	Electric battery right hand side	Lateral derecho batería eléctrica	Fianco sinistro batteria elettrica	Côté droit batterie électrique	Elektrische batterie rechte seite
3	00V03012	1	1	Electric battery left hand side	Lateral izquierdo batería eléctrica	Fianco destro batteria elettrica	Côté gauche batterie électrique	Elektrische batterie linke seite
4	00V03014	1	1	Resistor support	Soporte de resistencias	Sostegno resistenze	Support de résistances	Widerstands Ständer
5	1AC02259	6	9	Resistor 2000 W	Resistencia 2000 W	Resistenza 2000 W	Résistance 2000 W	Widerstand 2000 W



PLATON SERVICE
 8 (800) 500-34-41
 www.platonservice.com

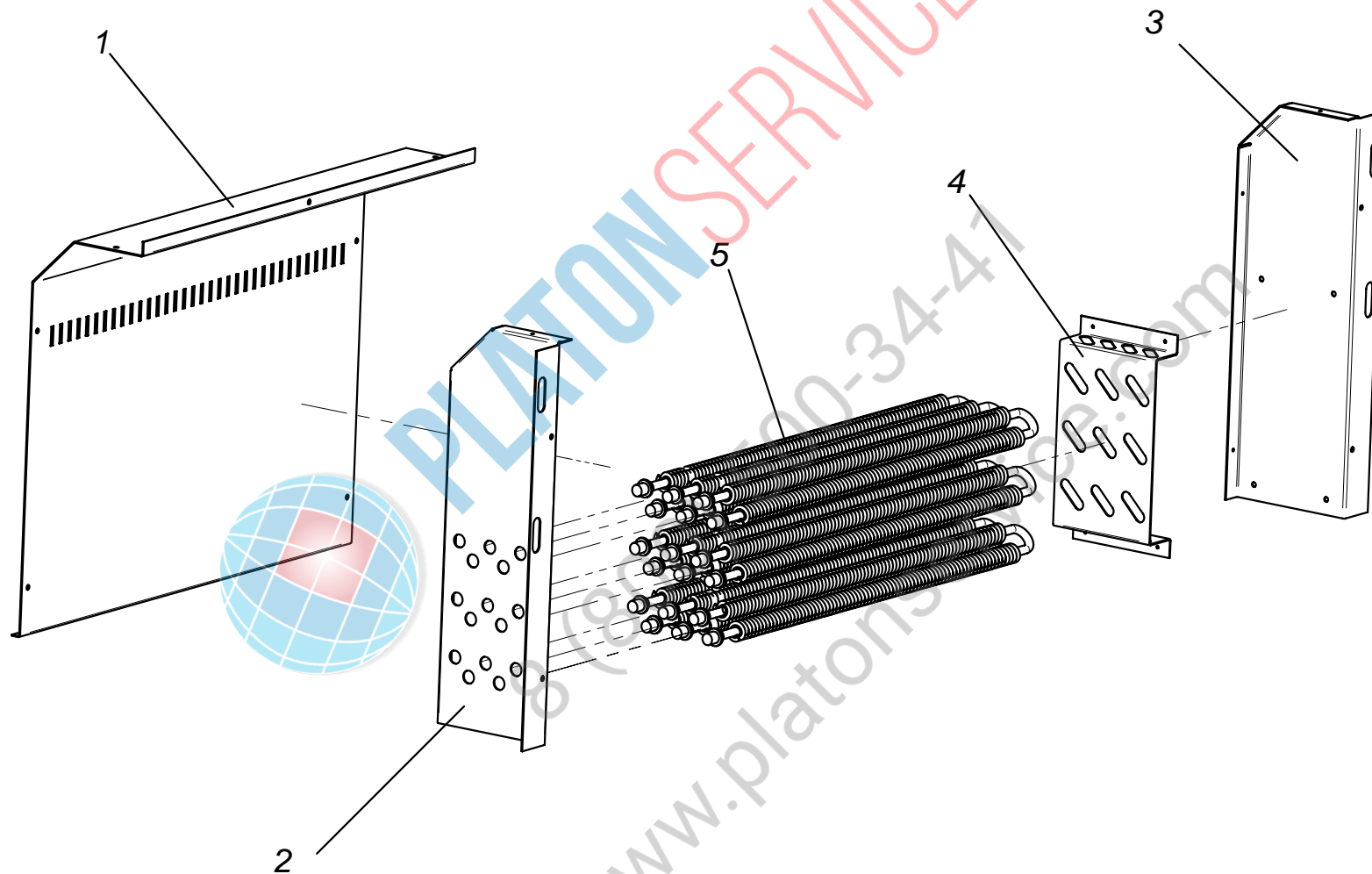

GAS HEATING / BATERIA GAS / BATTERIA GAS / CHAUFFAGE GAZ / GASHEIZUNG

Pos.	Código	10	3	Description	Descripción	Descrizione	Désignation	Bezeichnung
1	00V04005	1	1	Gas burner support	Soporte quemador gas	Supporto bruciatore	Support brûleur gaz	Gasbrennerhalterung
2	01V04004	1	1	Gas box	Caja gas	Cassetto gas	Boîte gaz	Gasbox
3	01V04006	2	2	Electrode support	Soporte electrodos	Supporto elettrodi gas	Support electrode	Elektrodenhalter
4	010Y0404	1	1	Gas box window	Ventana caja gas	Sportello ispezione fiamma	Hublot boîte gaz	Fenster gasbox
5	1AB01415	1	1	Gas electrovalve	Electroválvula gas	Elettrovalvola gas	Electrovanne gaz	Elektroventil f.gas
6	1AB01416	1	1	Ionization circuit	Círculo ionización	Basetta elettronica	Circuit ionisation	Ionisationskreis
7	1AB01418	2	2	Aluminium conection 90° 1/2"	Racor aluminio 90° 1/2"	Raccordo alluminio 90° 1/2"	Raccord aluminium 90° 1/2"	Alu-verschraubung 90° 1/2"
8	1AB01490	2	2	Electrode	Electrodo	Elettrodo	Electrode	Elektrode
9	1AB01625	1	1	Gas burner	Quemador gas	Bruciatore gas	Brûleur gaz	Gasbrenner
10	1AB01667	1	1	Injector 2,3 mm (GLP)	Inyector 2,3 mm (Gas propano)	Ugello gas GLP 195	Injecteur 2,3 mm (Gas propane)	Injektor 2,3 mm (Propangas)
	1AB01669	1	1	Injector 4,2 mm (Natural gas)	Inyector 4,2 mm (Gas natural)	Ugello gas metano 420	Injecteur 4,2 mm (gaz naturel)	Injektor 4,2 mm (Erdgas)
11	1AB01671	1	1	Support injector	Porta inyector	Supporto ugello	Support injecteur	Injektorhalter
12	1DK00002	2	2	Electrode conector	Terminal electrodos	Connettore elettrodo	Connecteur electrode	Elektrodenanschluss
13	1DL17000	1	1	Lighting ionization connector	Conector encendido-ionización gas	Connettore basetta	Connecteur allumage-ionisation gaz	Schalter zündung gas-ionisierung
14	1DO02030	0,7	0,7	Electrode cable	Cable para bujía	Cavo alta tensione	Cable electrode	Kabel für elektrode
15	1TN10016	1	1	Nut M16x1	Tuerca M16x1 latón	Dado M16x1	Écrou M16x1	Messingmutter M16x1
16	50782411	1	1	Connection Fig.241 1/2" 3/8"	Reducción latón Fig.241 1/2" 3/8"	Raccordo Fig.241 1/2" 3/8"	Raccord Fig.241 1/2" 3/8"	Reduktionsverschr Fig.241 1/2" 3/8"

GAS HEATING / BATERIA GAS / BATERIA GAS / CHAUFFAGE GAZ / GASHEIZUNG

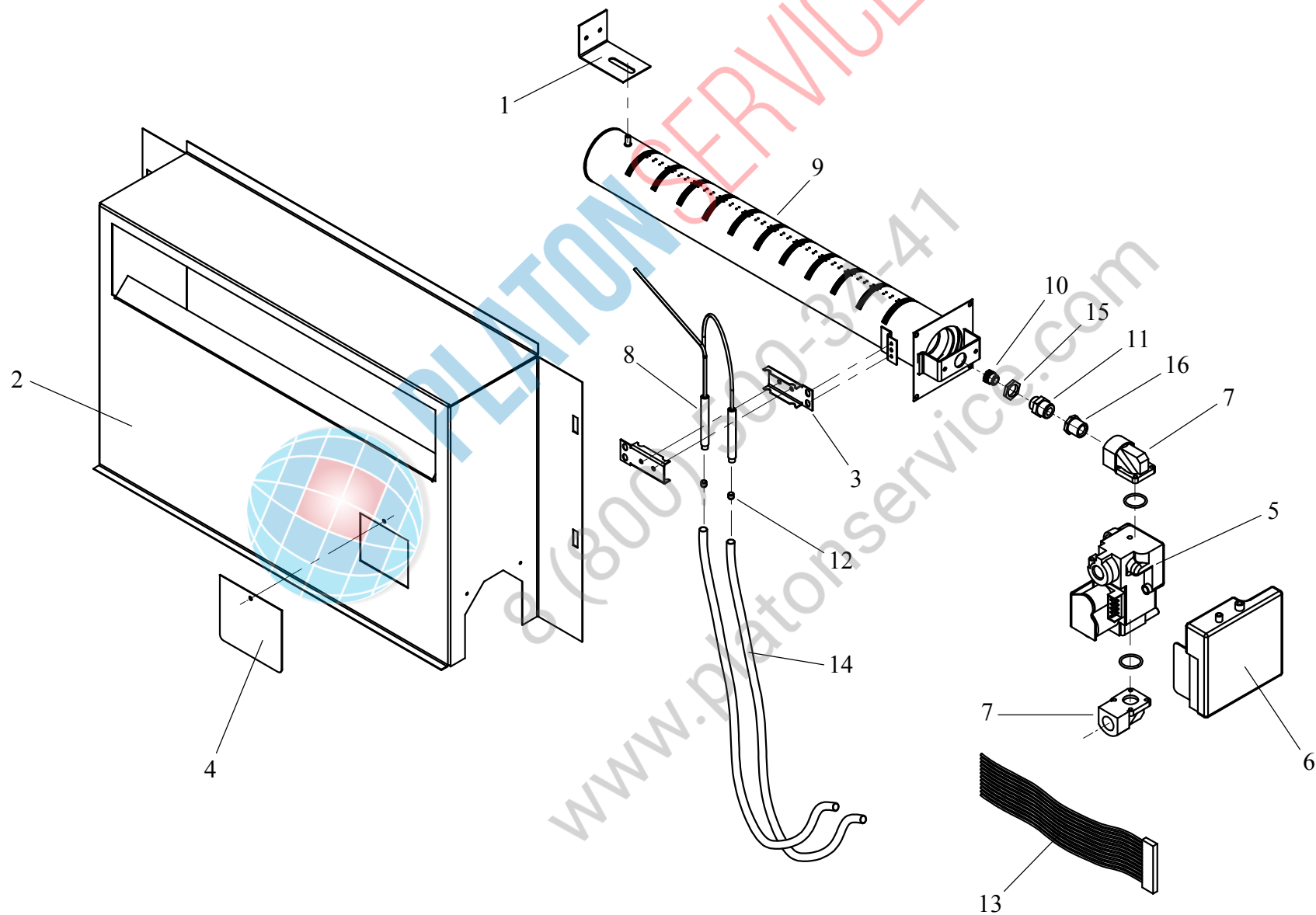

STEAM HEATING / BATERIA VAPOR / BATTERIA VAPORE / CHAUFFAGE VAPEUR / DAMPFHEIZUNG

Pos.	Código	10	3	Description	Descripción	Descrizione	Désignation	Bezeichnung
1	000Y0506	1	1	Steam battery cover	Tapa batería vapor	Coperchio batteria vapore	Couverture batterie vapeur	Dampfbatterie deckel
2	1JE80207	1	1	Steam electrovalve 1/2"	Electroválvula 1/2"	Elettrovalvola vapore 1/2"	Electrovanne vapeur 1/2"	Elektroventil 1/2"
3	800Z0500	1	1	Steam battery set	Conjunto batería vapor	Batteria vapore	Ensemble batterie vapeur	Dampfbatterie kompl.



PLATON SERVICE
 8 (800) 500-34-41
 www.platonservice.com

STEAM HEATING / BATERIA VAPOR / BATTERIA VAPORE / CHAUFFAGE VAPEUR / DAMPFHEIZUNG

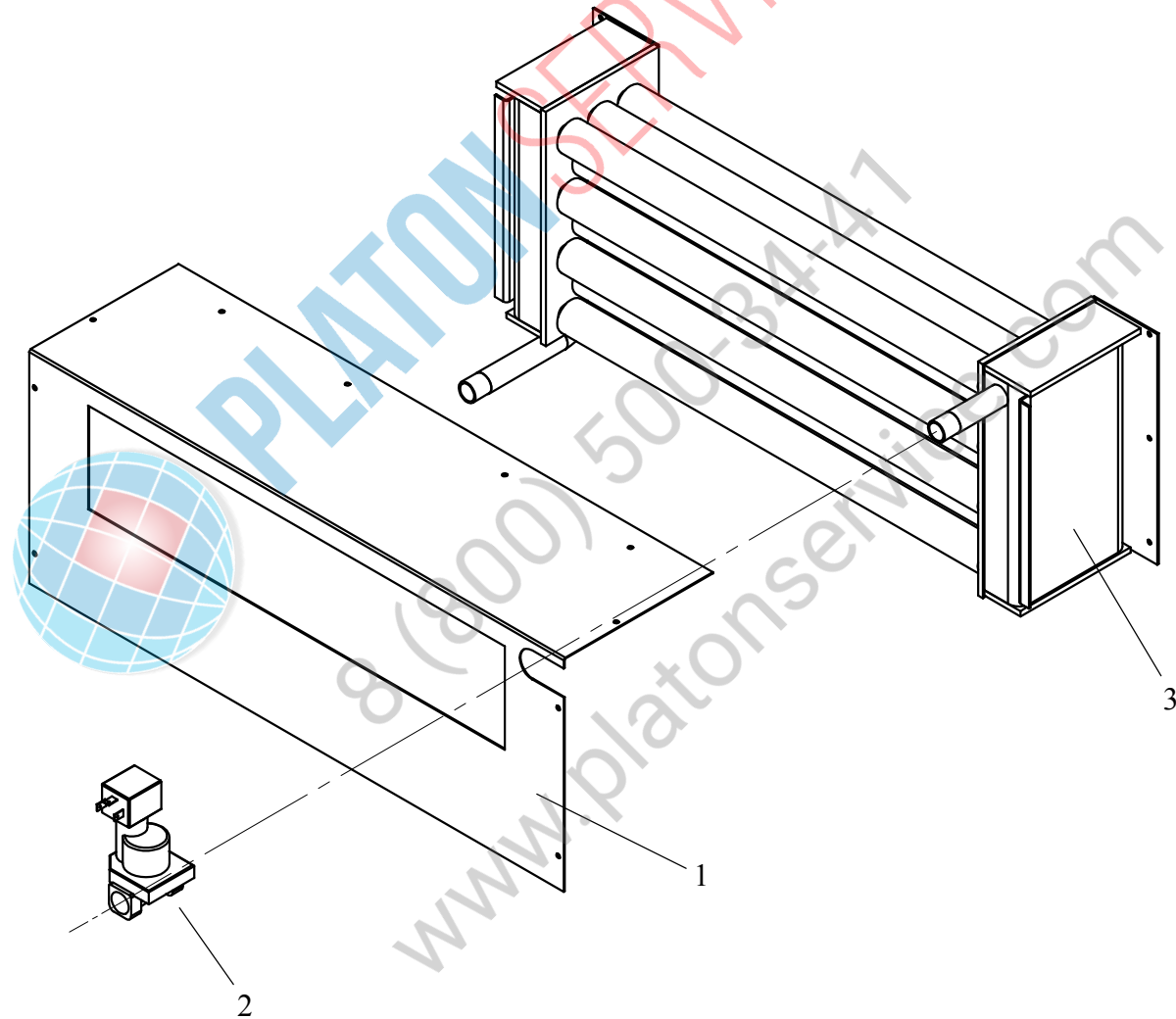

DOOR / PUERTA / PORTA / PORTE / TÜR

Pos.	Código	10	13	Description	Descripción	Descrizione	Désignation	Bezeichnung
1	00V02012	1	1	Door body	Cuerpo de la puerta	Oblò corpo	Corps porte	Tür Kegel
2	00V02022	1	1	Hidden hinge	Soporte bisagra	Cerniera oblò	Charnière cachée	Scharnier versteckt
3	1FB03044	1	1	Fix hinge	Bisagra fija	Cerniera fissa	Charnière fixe	Scharnier fixe
4	1FB03045	2	2	Movable hinge	Bisagra móvil	Cerniera mobile	Charnière mobile	Scharnier kamm
5	00V02060	1	1	Lid handle	Tirador	Maniglia	Poignée	Griff
6	1BG06061	1	1	Front door glass	Cristal frontal	Frontale vetro oblò	Frontale Vitrage porte	Vorderansicht Türglas
7	1BG06060	1	1	Back door glass	Cristal posterior	Schiena vetro oblò	Arrière vitrage porte	Unterer türglas
8	00V02150	1	1	Ring magnet	Ángulo soporte imán	Supporto magnetico	Support magnétique	magnethaltering
9	1FB02233	1	1	Magnet Ø13	Imán Ø13	Magnet Ø13	Aimant Ø13	Magnet Ø13
10	1BC03227	2	2	Fitting Ø10,8x15	Casquillo Ø10,8x15	Boccola Ø10,8x15	Fourreau Ø10,8x15	Buchse Ø10,8x15
11	00D32050	2	2	Door pin	Pasador bisagra	Perno di oblò fissaggio	Tourillon de fixation porte	Befestigungzapfen
12	00V00201	2	2	Stop magnet	Tope imán	Scontro magnet	Butée magnétique	Anschlag magnet
13	1BE03603	1	1	Rubber profile	Perfil de goma	Profilo in gomma	Profil de caoutchouc	Gummiprofil
14	1TO60351	8	8	Screw DIN 603 m5x10	Tornillos DIN 603 m5x10	Vite DIN 603 m5x10	Visser DIN 603 m5x10	Schraube DIN 603 m5x10



DOOR
PUERTA
PORTA
PORTE
TÜR

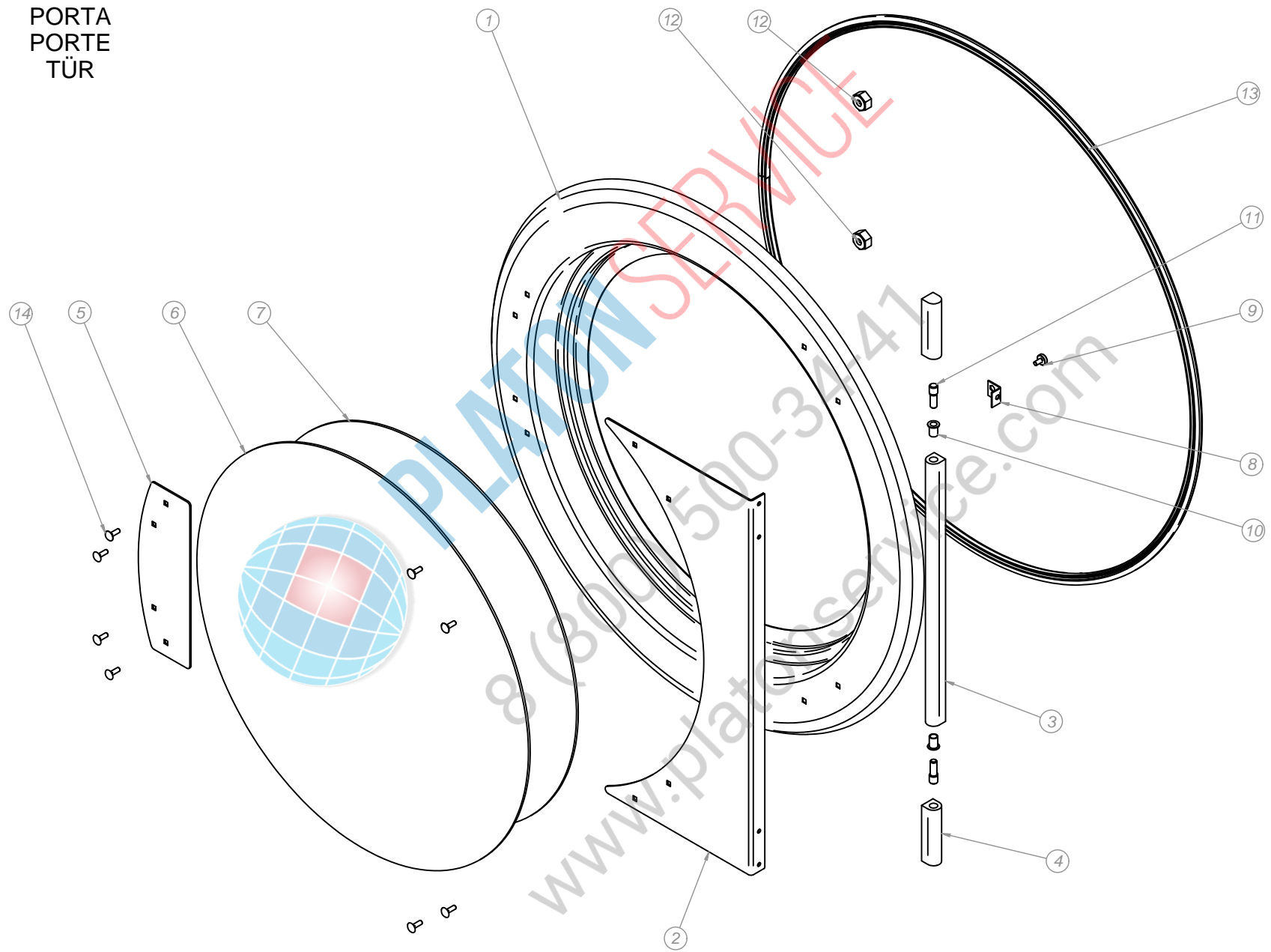

EXHAUST / VENTILACION / ASPIRAZIONE / VENTILATION / LÜFTUNG

ELECTRICAL HEATING / CALEFACCION ELECTRICA / RISCALDAMENTO ELETTRICO / CHAUFFAGE ELECTRIQUE / ELEKTRISCHE HEIZUNG

Pos.	Código	10	13	Description	Descripción	Descrizione	Désignation	Bezeichnung
1	1DE08312	1	1	Centrifugal fan	Ventilador centrífugo	Motoventilatore	Ventilateur centrifuge	Zentrifugalventilator
2	1DE08387	1	1	Fan protection	Rejilla ventilador	Piastra protezione ventilatore	Protecteur ventilateur	Ventilatorgitter



PLATON SERVICE
 8 (800) 500-34-41
www.platonservice.com

EXHAUST / VENTILACION / ASPIRAZIONE / VENTILATION / LÜFTUNG

GAS-STEAM HEATING / CALEFACCION GAS-VAPOR / RISCALDAMENTO GAS-VAPORE / CHAUFFAGE GAZ-VAPEUR / GAS-DAMPFHEIZUNG

Pos.	Código	10	13	Description	Descripción	Descrizione	Désignation	Bezeichnung
1	1DE08313	1	1	Centrifugal fan	Ventilador centrífugo	Motoventilatore	Ventilateur centrifuge	Zentrifugalventilator
2	1DE08387	1	1	Fan protection	Rejilla ventilador	Piastra protezione ventilatore	Protecteur ventilateur	Ventilatorgitter



PLATON SERVICE
 8 (800) 500-34-41
 www.platonservice.com

EXHAUST / VENTILACION / ASPIRAZIONE / VENTILATION / LÜFTUNG

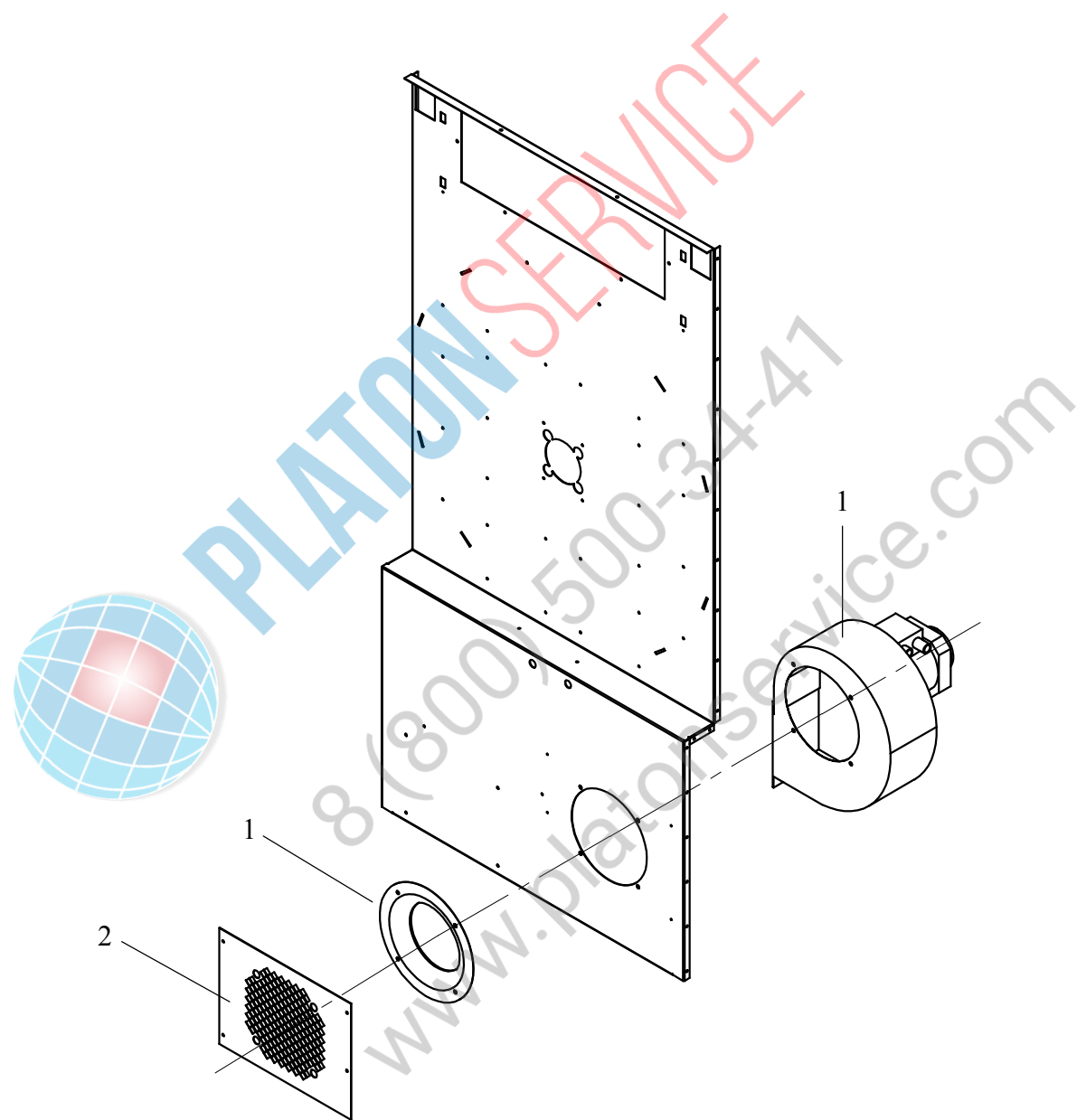

DRUM / TAMBOR / CESTO / TAMBOUR / TROMMEL

Pos.	Código	10	3	Description	Descripción	Descrizione	Désignation	Bezeichnung
1	00V01001	1	1	Axle-radium set	Conjunto eje-radios tambor	Albero completo di raggio	Ensemble axe-rayons	Achse-Speicher-Satz
2	00V01016	3	3	Drum reinforcement	Refuerzo tambor	Placca rinforzo cesto	Renforcement tambour	Trommelverstärkung
3	00V01017	3		Drum suspender M12	Tirantes tambor M12	Tirante cesto M12	Tenseur tambour M12	Trommelspannvorrichtung M12
	00V11017		3	Drum suspender M12	Tirantes tambor M12	Tirante cesto M12	Tenseur tambour M12	Trommelspannvorrichtung M12



PLATON SERVICE
 8 (800) 500-34-41
www.platonservice.com

DRUM / TAMBOR / CESTO / TAMBOUR / TROMMEL

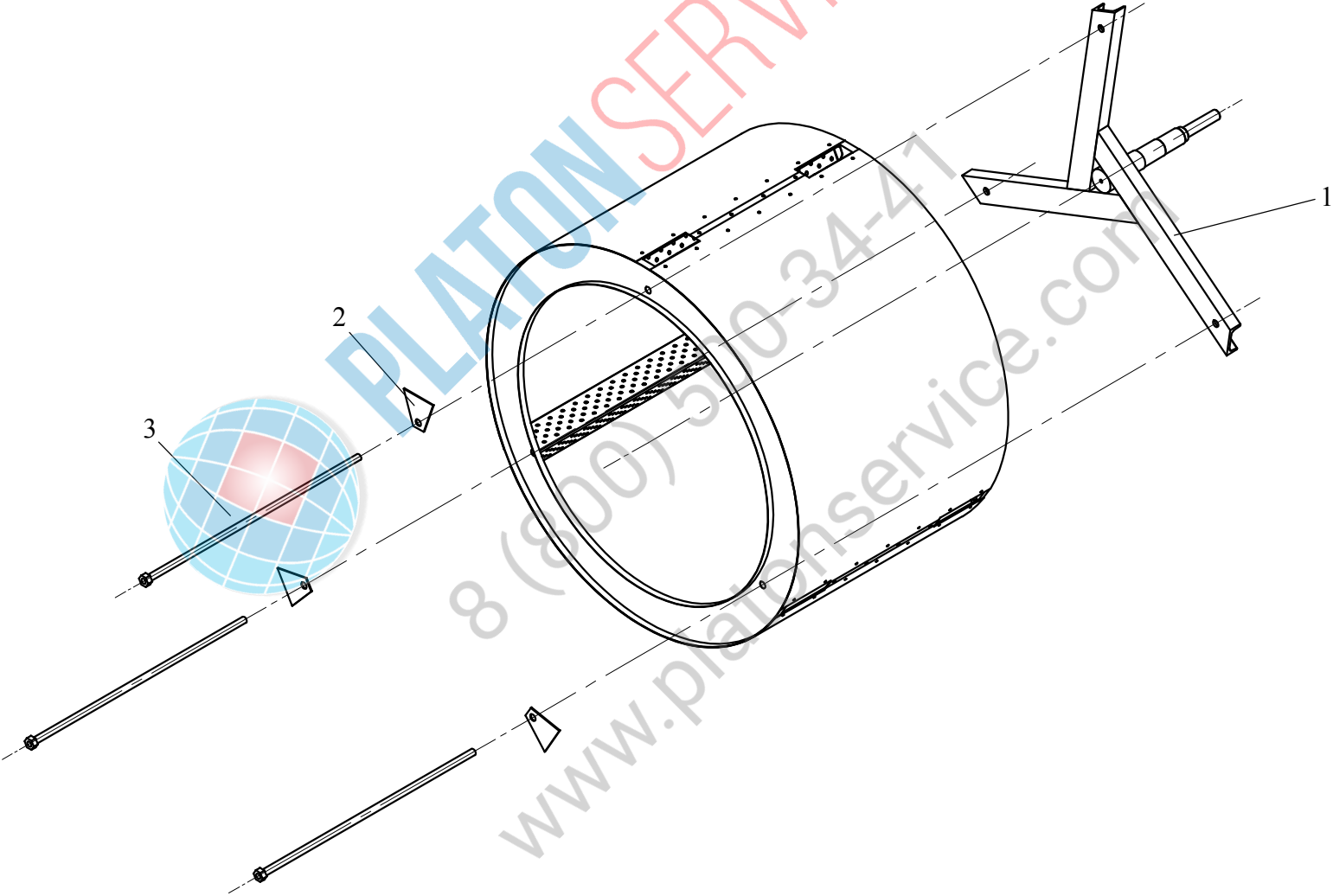

DRIVE / TRANSMISION / TRANSMISSIONE / TRANSMISSION / ÜBERTRAGUNG

Pos.	Código	10	3	Description	Descripción	Descrizione	Désignation	Bezeichnung
1	00V00078	1	1	Torque arm	Brazo de reacción reductor	Braccio blocca riduttore	Bras contre couple	Rückwirkungsarm
2	00V00079	1	1	Bearing support	Soporte rodamiento	Piastra supporto sede cuscinetti	Support roulement	Lagersitz
3	01V01019	1		Drum set 210	Conjunto tambor 210	Cesto 210	Ensemble tambour 210	Trommel kompl. 210
	01V11019		1	Drum set 330	Conjunto tambor 330	Cesto 330	Ensemble tambour 330	Trommel kompl. 330
4*	1DC07045	1	1	Gearbox motor	Motoreductor	Motore riduttore	Moteur reducteur	Motor reduktionsgetriebe
5	1ED40206	1	1	Bearing UCFC 206	Rodamiento UCFC 206	Cuscinetto con sede UCFC 206	Roulement UCFC 206	Lager UCFC 206
6	1ED40207	1	1	Bearing UCFC 207	Rodamiento UCFC 207	Cuscinetto con sede UCFC 207	Roulement UCFC 207	Lager UCFC 207
7	1GX10068	1	1	Key 8x7x60	Chaveta 8x7x60	Linguetta albero cesto 8x7x60	Clavette 8x7x60	Keil 8x7x60

4* A partir/From nº74848 subst. 1DC07056 GEARMOTOR + 1DC07057 MOTOR



PLATON SERVICE
8 (800) 500-34-42
www.platonservice.com

DRIVE / TRANSMISION / TRANSMISSIONE / TRANSMISSION / ÜBERTRAGUNG

